



# ceramica dolomite

## VASI E BIDET SOSPESI - ISTRUZIONI DI MONTAGGIO

## CUVETTES ET BIDET SUSPENDUS - INSTRUCTIONS DE MONTAGE

## WALL - MOUNTED WASHDOWN BOWLS AND BIDETS - ASSEMBLY INSTRUCTIONS

## WANDHANGENDE WC UND BIDET - MONTAGEANLEITUNG

STAFFE DI FISSAGGIO Art. J 117867	FIXATION Art. J 117867	FASTENING STIRRUPS Art. J 117867	HALTEBÜGEL Art. J 117867
<ul style="list-style-type: none"> <li>- Fissare le piastrine (E) alle barre filettate, assicurandosi che non sporgano dal dado di bloccaggio (F).</li> <li>- Inserire i bulloni (A) nei montanti (B).</li> <li>- Fissare le barrette (C) ai montanti con le apposite viti.</li> <li>- Bloccare i bulloni (A) alle quote indicate nelle tabelle quote installazione.</li> <li>- Incassare la staffa nel muro come indicato in fig[2].</li> <li>- Predisporre le tubazioni di alimentazione e scarico come indicato nelle tabelle "quote installazione".</li> </ul>	<ul style="list-style-type: none"> <li>- Fixer les plaquettes (E) sur les barres filetées (A) en s'assurant qu'elles ne dépassent pas en dehors de l'écrou de blocage (F).</li> <li>- Insérer les boulons (A) dans les montants (B).</li> <li>- Fixer avec les vis spéciales les petites barres (C) aux montants.</li> <li>- Bloquer les boulons (A) aux cotes indiquées dans les tableaux "cotes d'installation".</li> <li>- Encaisser le châssis, dans le mur comme indiqué sur la fig[2].</li> <li>- Préparer les tuyauteries d'alimentation et de vidage selon les tableaux "cotes d'installation".</li> </ul>	<ul style="list-style-type: none"> <li>- Fasten the plates (E) to the threaded bars (A) checking that they do not project from the fastening nut (F).</li> <li>- Insert bolts (A) in the struts (B).</li> <li>- Fasten the bars (C) to the struts with the suitable screws.</li> <li>- Adjust the bolts (A) to the level shown in the "installation level" tables.</li> <li>- Place the frame into the wall as shown in picture[2].</li> <li>- Prepare water supply and drain pipes as shown in the "installation level" tables.</li> </ul>	<ul style="list-style-type: none"> <li>- Befestigen Sie die Gewindeplatten (E) auf der Gewindestange (A) und vergewissern Sie sich, daß Sie nicht über die Befestigungsmutter (F) hinausragen.</li> <li>- Führen Sie die Gewindestange (A) in Halter (B) ein.</li> <li>- Befestigen Sie die Stäbe (C) an den Haltern.</li> <li>- Blockieren Sie die Gewindestange (A) auf der in der Tabelle "Installationsmaße" angegebenen Maß mit Mutter und Scheibe.</li> <li>- Betten Sie den Rahmen in die Wand wie gem. Zchg[2].</li> <li>- Verlegen Sie die Zufluß- und Abflußrohrleitungen wie in den Tabellen "Installationsmaße".</li> </ul>

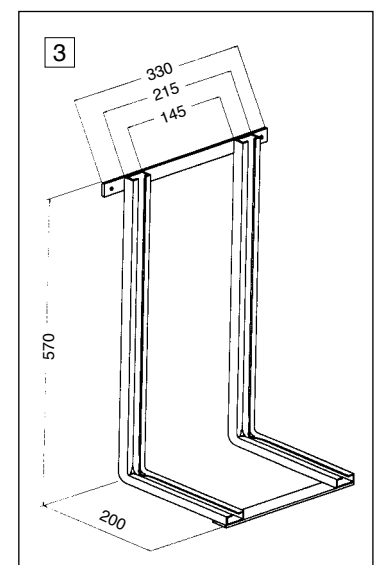
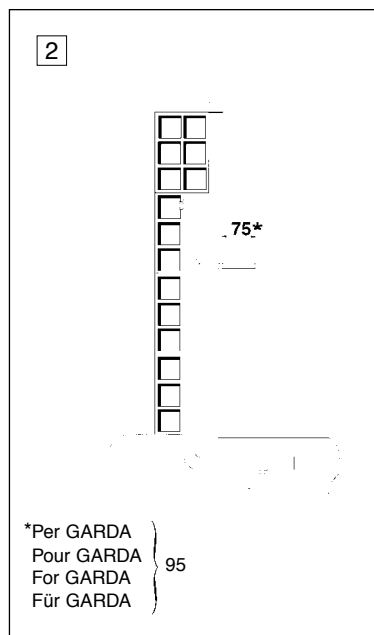
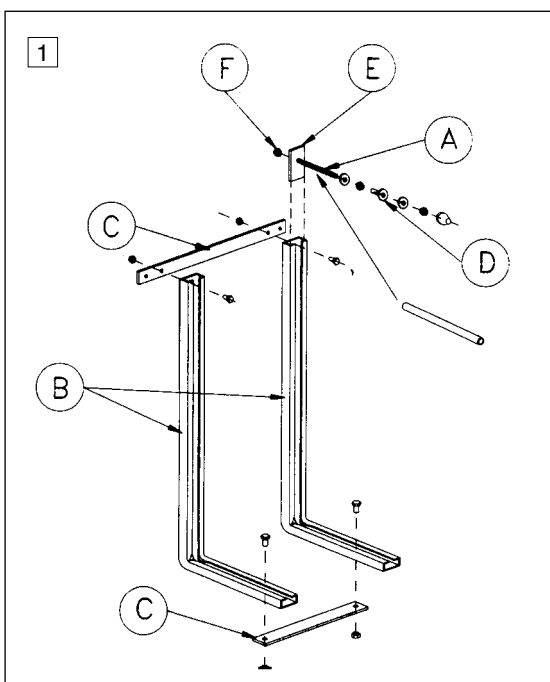

CERAMICA DOLOMITE

Via Cavassico Inf. 160 - 32028 Trichiana (BL)  
Tel. 0437/5581 - Fax 0437/754383

QUOTE INSTALLAZIONE	COTES D'INSTALLATION	INSTALLATION LEVEL	MONTAGE MASSE
Le quote sono riferite ad un'altezza dei sanitari di mm 400, dal pavimento finito, misurata nella parte anteriore.	La hauteur des sanitaires est de 400 mm. à partir du sol fini, mesurée sur le devant.	Considering the fixtures as 400 mm. high from the finished floor, measured from their front part.	Beachten Sie, daß die Höhe der Sanitäreinrichtungen 400 mm. vom fertigen Fußboden ist und an der Vorderseite derselben gemessen wird.

## BIDET

Alimentazione all'interno della carenatura  
Supply inside the fairing  
Alimentation à l'intérieur de l'habillage  
Versorgung im Innern der Verkleidung

Alimentazione all'esterno della carenatura  
Supply outside the fairing  
Alimentation à l'extérieur de l'habillage  
Versorgung außerhalb der Verkleidung

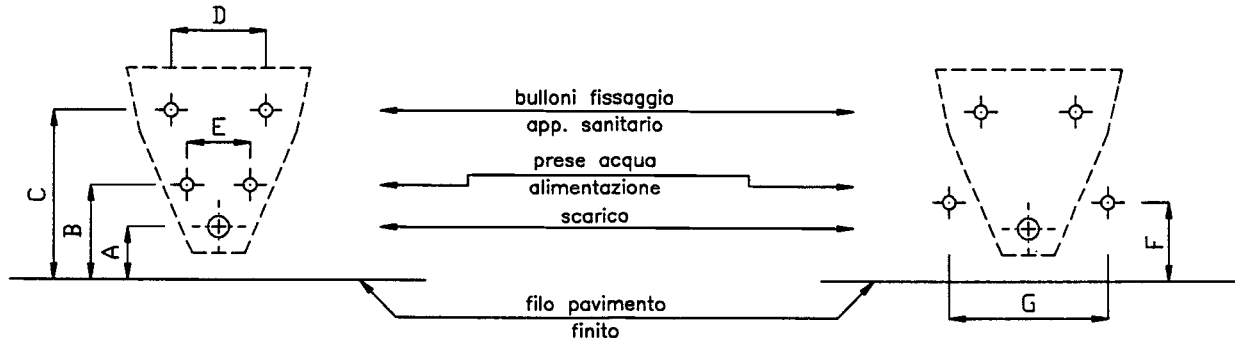

Marchio	Serie	A	B	C	D	E	F	G
		mm.	mm.	mm.	mm.	mm.	mm.	mm.
<b>DOLOMITE</b>	PIANO DESIGN	110	170	330	180	100	=	=
	SWEET LIFE	120	80	340	180	130	=	=
	RIO	100	180	320	180	120	150	300
	ASOLO	140	260	335	180	80	=	=
	DAHLIA	95	180	310	180	120	125	380
	CLODIA	100	200	310	180	130	150	300
	ZELIG	150	120	345	180	130	=	=
	NOVELLA	100	190	325	180	120	130	380
	GARDA	100	185	330	180	110	130	320
<b>SENESI</b>	PIENZA	100	200	325	180	130	170	380
	PALIO	100	170	310	180	70	130	360
	DONATELLO	80	190	330	180	120	130	380

## VASO - MONOBLOC

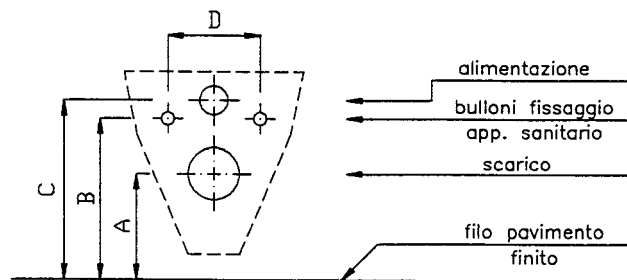

Marchio	Serie	A	B	C	D
		mm.	mm.	mm.	mm.
<b>DOLOMITE</b>	PIANO DESIGN VASO	225	330	360	180
	PIANO DESIGN MONOBLOC	225	330	=	180
	SWEET LIFE VASO	235	340	370	180
	RIO VASO	205	310	345	180
	RIO MONOBLOC	205	310	710	180
	ASOLO	235	335	367	180
	DAHLIA VASO	210	310	350	180
	CLODIA VASO	210	310	345	180
	ZELIG VASO	248	346	378	180
	NOVELLA VASO	225	325	360	180
	GARDA VASO	230	330	365	180
	GARDA MONOBLOC	230	330	730	180
	<b>SENESI</b>	PIENZA VASO	230	330	365
PALIO VASO		200	300	335	180
DONATELLO VASO		225	325	360	180